

S. Soare, V. Zoita, T. Craciunescu, M. Curuia, V. Kiptily, I. Lengar, A. Murari, P. Prior, M. Anghel, G. Bonheure, M. Constantin, E. David, T. Edlington, D. Falie, S. Griph, F. LeGuern, Y. Krivchenkov, M. Loughlin, A. Pantea, S. Popovichev, V. Riccardo, B. Syme, V. Thompson, I. Tiseanu and JET EFDA contributors

Upgrade of the JET Gamma-Ray Cameras

"This document is intended for publication in the open literature. It is made available on the understanding that it may not be further circulated and extracts or references may not be published prior to publication of the original when applicable, or without the consent of the Publications Officer, EFDA, Culham Science Centre, Abingdon, Oxon, OX14 3DB, UK."

"Enquiries about Copyright and reproduction should be addressed to the Publications Officer, EFDA, Culham Science Centre, Abingdon, Oxon, OX14 3DB, UK."

Upgrade of the JET Gamma-Ray Cameras

S. Soare¹, V. Zoita², T. Craciunescu², M. Curuia¹, V. Kiptily³, I. Lengar⁴, A. Murari⁵, P. Prior³,
M. Anghel¹, G. Bonheure⁶, M. Constantin¹, E. David¹, T. Edlington³, D. Falie², S. Griph³,
F. Le Guern⁷, Y. Krivchenkov³, M. Loughlin³, A. Pantea², S. Popovichev³, V. Riccardo³,
B. Syme³, V. Thompson³, I. Tiseanu² and JET EFDA contributors*

JET-EFDA, Culham Science Centre, OX14 3DB, Abingdon, UK

¹Association EURATOM-MEdC, National Institute for Cryogenics and Isotopic Technologies, Rm. Valcea, Romania

²Association EURATOM-MEdC, National Institute for Laser, Plasma and Radiation Physics, Bucharest, Romania

³Association EURATOM-UKAEA/JOC, Culham Science Centre, OX14 3DB, Abingdon, OXON, UK

⁴Association EURATOM-MHST, Jozef Stefan Institute, Ljubljana, Slovenia

⁵Association EURATOM-ENEA, RFX, Padova, Italy

⁶Association EURATOM-Belgian State, LPP-ERM/KMS, B 1000 Brussels, Belgium

* See annex of M.L. Watkins et al, "Overview of JET Results",
(Proc. 21st IAEA Fusion Energy Conference, Chengdu, China (2006)).

Preprint of Paper to be submitted for publication in Proceedings of the
International Workshop on Burning Plasma Diagnostics, Villa Monastero, Varenna, Italy.
(24th September 2007 - 28th September 2007)

ABSTRACT.

The JET gamma-ray camera diagnostics have already provided valuable information on the gamma-ray imaging of fast ion in JET plasmas [1, 2]. The applicability of gamma-ray imaging to high performance deuterium and deuterium-tritium JET discharges is strongly dependent on the fulfilment of rather strict requirements for the characterisation of the neutron and gamma-ray radiation fields. These requirements have to be satisfied within very stringent boundary conditions for the design, such as the requirement of minimum impact on the co-existing neutron camera diagnostics. The JET Gamma-Ray Cameras (GRC) upgrade project deals with these issues with particular emphasis on the design of appropriate neutron/gamma-ray filters (“neutron attenuators”). Several design versions have been developed and evaluated for the JET GRC neutron attenuators at the conceptual design level. The main design parameter was the neutron attenuation factor. The two design solutions, that have been finally chosen and developed at the level of scheme design, consist of: a) one quasi-crescent shaped neutron attenuator (for the horizontal camera) and b) two quasi-trapezoid shaped neutron attenuators (for the vertical one). The second design solution has different attenuation lengths: a short version, to be used together with the horizontal attenuator for deuterium discharges, and a long version to be used for high performance deuterium and DT discharges. Various neutron-attenuating materials have been considered (lithium hydride with natural isotopic composition and ^6Li enriched, light and heavy water, polyethylene). Pure light water was finally chosen as the attenuating material for the JET gamma-ray cameras. The neutron attenuators will be steered in and out of the detector line-of-sight by means of an electro-pneumatic steering and control system. The MCNP code was used for neutron and gamma ray transport in order to evaluate the effect of the neutron attenuators on the neutron field of the JET GRC. The modelling was dedicated to the estimation of neutron and (plasma-emitted) gamma-ray attenuation, neutron-induced gamma-ray background and the neutron in-scattering impact on the neutron detectors due to the attenuator in the parking location. A numerical study of the gamma-ray detector (CsI(Tl)) was done by means of the IST Monte Carlo code. It provided preliminary results on the detector efficiency and response function.

1. INTRODUCTION

The JET gamma-ray camera diagnostics system (KN3 neutron/gamma-ray profile monitor) has already provided valuable information on the fast ion evolution in JET plasmas [1, 2]. The applicability of gamma-ray imaging diagnostics to high power deuterium and deuterium-tritium discharges is strongly dependent on the fulfilment of rather strict requirements for the control of the neutron and gamma-ray radiation fields. These requirements were augmented by the very hard design restrictions on JET (e.g., the requirement of minimum effects on the co-existing neutron camera diagnostics).

The main objective of the JET Enhancements (EP2) gamma-ray camera diagnostics upgrade is the design, construction and testing of neutrons attenuators for the two sub-systems of the KN3 gamma-ray imaging diagnostics: a) KN3 gamma-ray horizontal camera (KN3 HC) and b) KN3 gamma-ray vertical camera (KN3 VC). This diagnostics upgrade should make possible gamma-ray imaging measurements in high power deuterium JET pulses, and eventually in deuterium-tritium discharges.

Another objective of this upgrade project is to develop and test design solutions of relevance to ITER. Eventually, the JET KN3 gamma-ray cameras diagnostics upgrade should validate design solutions of interest for ITER.

2. JET GAMMA-RAY CAMERA NEUTRON ATTENUATORS

Several design versions were developed and evaluated for the JET gamma-ray camera neutron attenuators at the conceptual design level. The main design parameter was the neutron attenuation factor. The following design solutions were finally chosen and developed at the level of scheme design:

- One quasi-crescent shaped neutron attenuator for the horizontal camera
- Two quasi-trapezoid shaped neutron attenuators for the vertical camera, with different attenuation lengths: a short version, to be used together with the horizontal attenuator for deuterium discharges and a long version to be used for high performance deuterium and DT discharges.

The locations of the neutron attenuators are shown schematically in Figure 1 together with the detector lines of sight of each of the two KN3 cameras. The components of the steering and control system are also shown (LUC, Local Unit Cubicle). The attenuators are placed within the KN3 diagnostics system in Octant 1 between the vacuum port and the collimator body (also called “radiation shield”), both in the case of the Horizontal Camera (HC) and Vertical Camera (VC) (Figure 1). The position of the neutron attenuators are is steered and controlled by a commercially available electro-pneumatic system and several additional custom-tailored parts (Figure 1).

The horizontal camera neutron attenuator is designed to function as a neutron filter when in working position (in the plane determined by the gamma-ray detectors lines of sight). To move the neutron attenuator to and from the working position two movements are required: first a 90° rotation (to the right when looking to plasma) and second a 630mm translation as shown in Figure 2.

The horizontal camera neutron attenuator (HC_NA) consists of a metal casing filled with the pure light water (as attenuating material) and a U-shaped profile that provides the structure with mechanical strength and connects with the steering and control system (Figure 2).

The vertical camera neutron attenuator (VC_NA) is positioned on Octant 1, inside the KS3 optical diagnostics box (Figure 3). To move in and out of the working location the attenuator is translated 100mm by the steering and control electro-pneumatic system. Both vertical camera attenuator casings (short and long version) have a quasi-trapezoidal shape with internal reinforcements parallel to and between the lines of sight.

Both attenuators, of horizontal and vertical cameras, are situated in strong poloidal magnetic fields generated by the nearby poloidal and shaping coils. The vertical camera neutron attenuator is in a worse situation than that of the horizontal camera, due to larger torques from different directions. Finite Element Analysis was used to evaluate the casings deformation and stresses when subjected to torques larger than those thought to exist. Results suggest there is no cause of concern from this point of view.

3. RADIATION (NEUTRON AND PHOTON) ANALYSIS OF THE GAMMA-RAY CAMERA NEUTRON ATTENUATORS

Monte Carlo (MCNP) [3] calculations of the neutron and photon transport were carried out for the vertical camera neutron attenuator and addressed to the following matters: attenuation factors for neutrons and plasma-emitted gamma-rays in the neutron attenuator; neutron induced gamma-rays in the neutron attenuator; relative level of the in-scattering of neutrons into the detector region from the attenuator in the parking position. The following results were obtained:

- attenuation factors (vertical camera neutron attenuator, short version) for 2.45MeV neutrons: approximately 10^2 (short attenuator), and 10^4 (long attenuator)
- transmission of the plasma-emitted gamma-rays varies with photon energy from approximately 20% at 2MeV to about 60% at 10MeV
- level of the neutron in-scattering into the detector region from the vertical camera attenuator placed in parking position is estimated to be less than 3% of the overall in-scattering due to the collimator body (KN3 shield).

The influence of different CsI(Tl) gamma-ray detector geometries for an optimum detector response in the case of KN-3 gamma-ray imaging was analysed by means of the Integrated TIGER Series (ITS) Monte Carlo electron/photon radiation transport code [4]. The calculations were done for channel 15 (central channel) of the KN-3 vertical camera and they provided an evaluation of the global detector response. The response function of the CsI(Tl) detector was also calculated for the 1-10 MeV energy range using 256 energetic channels.

CONCLUSIONS

The design of the upgraded JET KN3 gamma-ray camera diagnostics has been developed up to the scheme design level. All issues regarding the impacts on adjacent systems (“interfaces”) were addressed and adequate design solutions were developed. The analysis of the mechanical behaviour showed that the deformations were insignificant and will not present any causes of concern. The severe design constraints limited the attainable parameters of the upgraded gamma-ray cameras. The upgraded GRC diagnostics will work as a two-camera system for low power JET pulses and as a single (vertical) camera for high power deuterium and deuterium-tritium pulses. The addition of the neutron attenuators for the KN3 gamma-ray cameras has no significant impact on the co-existing neutron camera diagnostics.

REFERENCES

- [1]. V. Kiptily et al., this conference
- [2]. V. Kiptily et al., Plasma Phys. Control. Fusion, **48** (2006) R59–R82
- [3]. Briesmeister J. F., Ed., “MCNP-A General Monte Carlo N-Particle Transport Code, Version 4C”, LA-13709-M (April 2000)
- [4]. Halbleib J.A. et al., “ITS version 3–The integrated TIGER series of Coupled Electron/Photon Monte Carlo Transport Code”, Sandia National Laboratories.

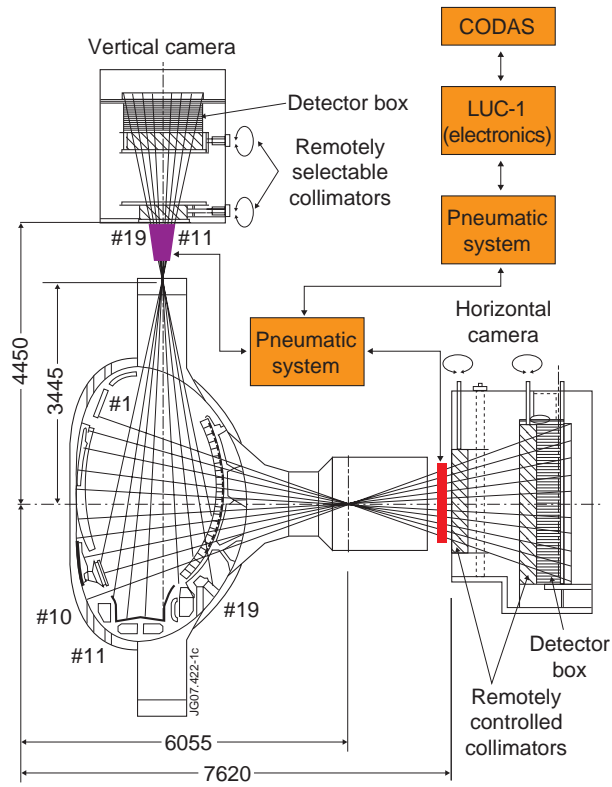

Figure 1: JET KN3 neutron/gamma diagnostics with neutron attenuators and their command and steering system.

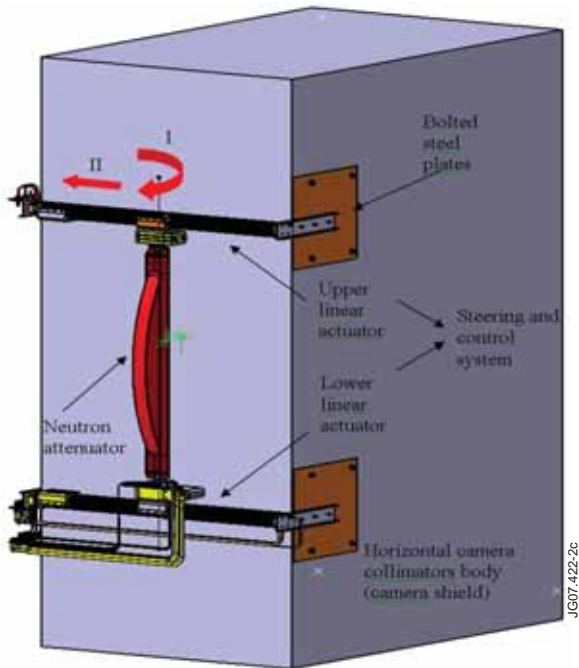

Figure 2: Horizontal Camera Neutron Attenuator in working position.

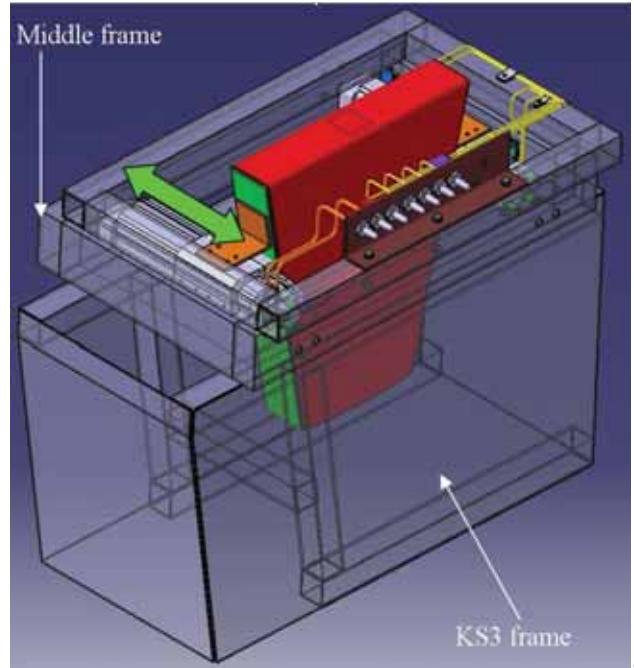

Figure 3: Vertical Camera Neutron Attenuator in working position.